

OWNER'S MANUAL

TRC-475 40-CHANNEL CITIZENS BAND WEATHERADIO

Please read before using this equipment

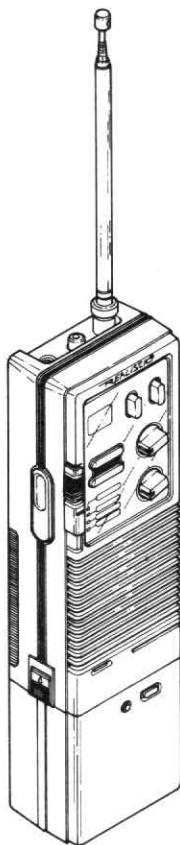

Cat. No. 21-1515

REALISTIC[®]

INTRODUCTION

Your Realistic[®] TRC-475 is a 40-channel CB radio that is specially designed for emergency situations. It comes with a handy carrying case so that you can easily move it from one vehicle to another. And, the TRC-475 is also a 3-channel weatheradio. You can use it to receive weather information 24 hours a day.

You can power the TRC-475 from the cigarette lighter in any vehicle that has a 12-volt, negative ground electrical system. However, you can also power the unit using the supplied battery pack if your vehicle battery is dead or if you must leave the vehicle in an emergency situation.

The TRC-475 comes with a telescoping magnetic-mount antenna that is designed for use when your vehicle is not moving. If you plan to use the radio when the vehicle is moving, we suggest that you obtain a standard magnetic-mount antenna.

If you must use the TRC-475 away from your vehicle, you can remove the supplied telescoping antenna from its magnetic base and attach it directly to the radio. Other features include:

Emergency Channel 9 Switch—lets you immediately switch to Channel 9, the universal emergency channel.

PLL (Phase-Locked Loop) Tuning—generates 40 precise CB channel frequencies from a single crystal.

Digital Channel-Number Display—makes it easy to see which channel you have selected.

Range Control—lets you eliminate background noise when no strong signals are present.

CB/WEATHERADIO Switch—lets you quickly switch from CB to weatheradio operation.

Built-in Ceramic Filters—assure superior selectivity and freedom from adjacent channel interference.

Built-in Automatic Noise Limiter—helps reduce interference noise.

External Antenna Jack—with an optional adapter, lets you connect the TRC-475 to practically any CB radio antenna.

No FCC License Required (USA)—You can operate a CB radio in the USA without a license. However, you must know Part 95 of the FCC rules and regulations. It explains the proper operation of a class D citizen's band unit. A copy of Part 95 is enclosed with your CB radio.

For your own protection, we urge you to record the serial number of this unit in the space below. You'll find the serial number on the back of the radio.

Serial Number: 3409866

A QUICK LOOK AT YOUR TRC-475

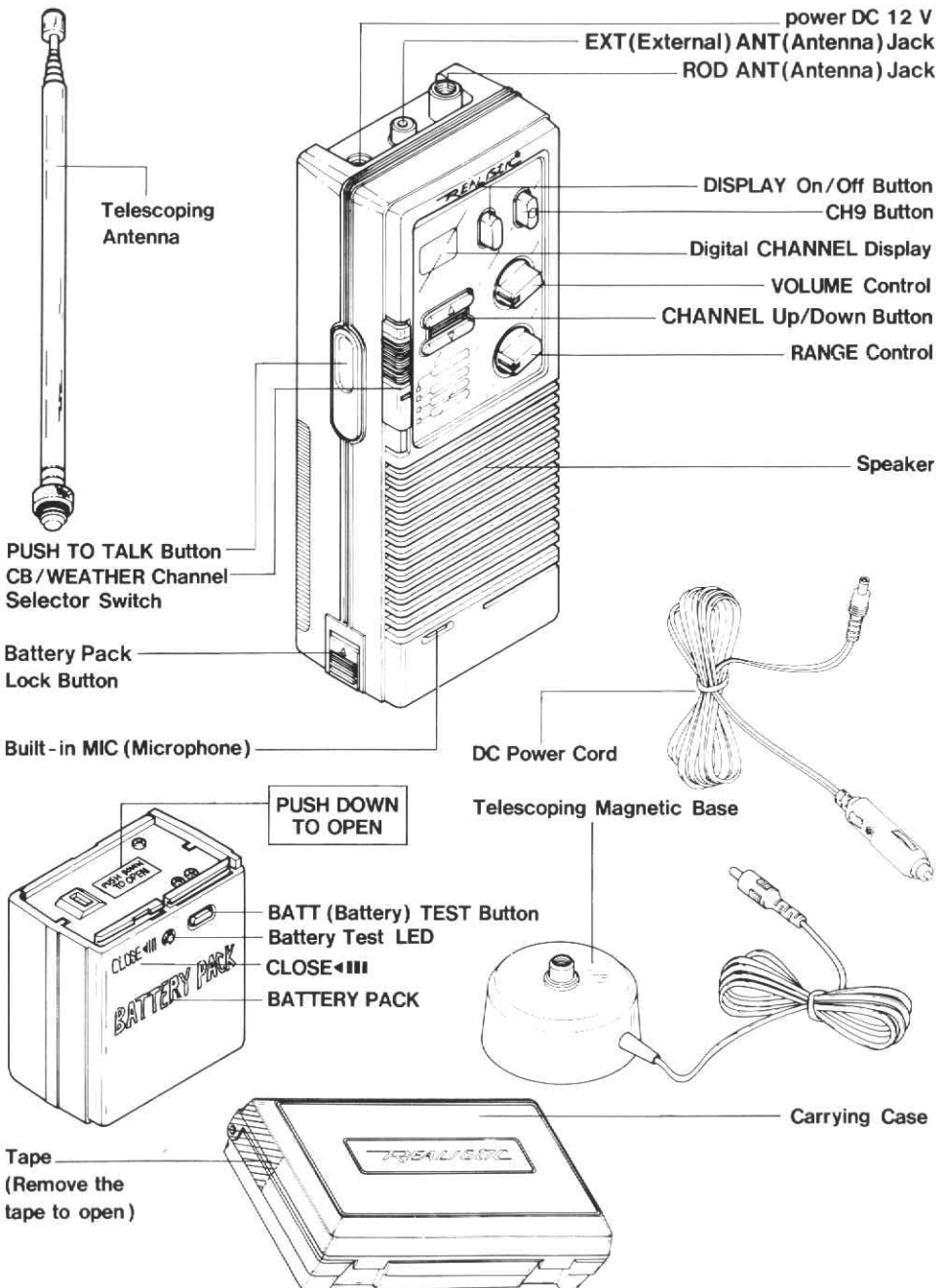

PREPARATION FOR USE

ATTACHING THE DC POWER CORD

The primary power source for the TRC-475 is the cigarette lighter of your vehicle (car, boat, RV, and so on). Use the supplied DC power cord to connect to this power as follows:



1. Plug the small end of the power cord into the power DC 12V jack on the top of the radio.
2. Then, plug the other end of the power cord into the cigarette lighter socket.

Notes:

- If the TRC-475 does not operate properly when you are using the DC power cord, check to be sure the lighter socket is clean and free of ash build up.
- If the unit still doesn't work, check the fuse in the cigarette lighter plug and, if necessary, replace the fuse as follows.

REPLACING THE POWER CORD'S FUSE

The power cord's fuse is located inside the plug.



1. Remove the plug's tip by turning it counterclockwise.
2. Then, insert a new 2-amp, 125-volt fuse and replace the tip.

Caution: Never replace the fuse with one that has a rating higher than 2-amp. This could damage the radio and/or your vehicle.

INSTALLING BATTERIES IN THE BATTERY PACK

If you cannot connect the TRC-475 to your vehicle's battery in an emergency, you can use the battery pack for power. Install the batteries in the battery pack and attach the battery pack to the radio as follows.

Note: When you connect the DC power cord, the battery pack is automatically disconnected.

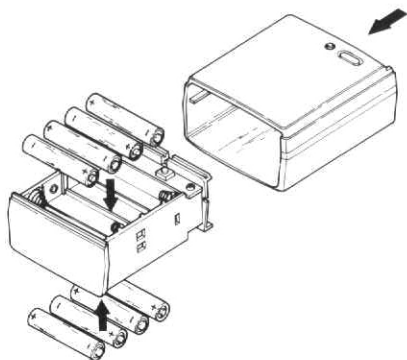

1. Remove the battery holder from the battery pack's case by pushing down on the top-center of the battery pack.
2. Install eight AA extra-life (Radio Shack Cat. No. 23-582) or alkaline (Cat. No. 23-552) batteries in the battery holder, observing the polarity (+ and -) marked on the holder.
3. From the side of the radio, slide the battery pack onto the bottom of the radio until it snaps into place.

Note: To remove the battery pack, press the battery pack latch up, and slide the battery pack off to the side.

CHECKING THE BATTERIES

The battery pack has a [BATT TEST] button and indicator that lets you test the batteries. Simply press [BATT TEST]. If the indicator lights, the batteries are still good. If the indicator does not light, replace all eight batteries to assure continuous operation of the radio.

ATTACHING THE ANTENNA

You can attach the supplied telescoping antenna in one of two ways. If you are using the radio in your vehicle, use the magnetic base. If you must use the radio away from the vehicle (with the battery pack), you can attach the antenna directly to the radio. In either case, fully extend the antenna for maximum range.

Using the Antenna's Magnetic Base

When your vehicle is not moving, attach the telescoping antenna to the magnetic base and place the base as near as possible to the center of your vehicle's roof. Then, plug the antenna wire into the radio's EXT ANT jack.

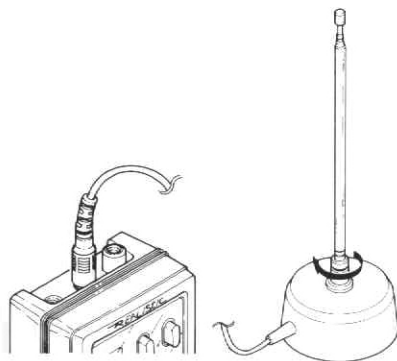

If you want to use the radio when the vehicle is moving, you must obtain an optional standard magnetic-mount antenna (available at your local Radio Shack store). You also need a plug adapter to convert a standard antenna's PL-259 plug to an RCA-type plug (278-208).

Attaching The Antenna Directly To The Radio



To attach the antenna directly to the radio, simply unscrew the antenna from the magnetic base and attach the antenna to the radio's ROD ANT connector.

OPERATION

USING THE CB RADIO

First, connect a power source and an antenna to the radio as described earlier in the manual. Be sure to fully extend the antenna and, if you are using the magnetic base, place it near the center of your vehicle's roof.

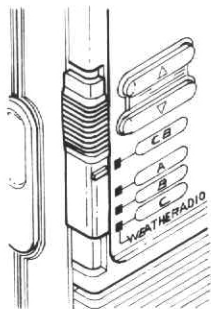

1. Set the CB/WEATHER RADIO switch to CB.
2. Turn the VOLUME control clockwise so that the radio clicks on.
3. Set the RANGE control as desired. See "Setting the Range Control".
4. Press the [DISPLAY] to the out position to turn on the display.

Note: After you select the desired channel, you can press the [DISPLAY] to the in position to turn off the display and save power.

5. Press the CHANNEL [Δ] or [∇] button to scan to the desired channel.

Note: In an emergency situation, you can simply press [CH9] to the *in* position to send/receive on Channel 9, whether or not the display is on.

6. To transmit, press the upper end of the [PUSH TO TALK] button and speak directly into the built-in microphone. To receive, simply release the [PUSH TO TALK] button.

7. Adjust the VOLUME control as desired.

The VOLUME and RANGE controls only affect reception. They have no effect on your transmission range.

Setting The Range Control

Because this is primarily a emergency radio, we suggest you leave the RANGE control set fully counterclockwise when you store the radio. This assures the maximum reception range in an emergency situation.

RANGE

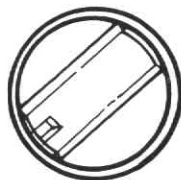

If you want to eliminate background noise when you are not receiving a strong signal from another CB radio, wait until you are not receiving a call and turn the control clockwise until the background noise stops.

USING THE WEATHERADIO

In the USA, detailed weather information is continuously broadcast on 372 government weather stations. Each of these stations broadcast on 162.400 (A), 162.475 (B), 162.550 (C) MHz.

Most of the weather stations use the C frequency, but in locations where there might be interference between stations, the other two frequencies might be used. Choose the frequency that provides the best reception in your area.

To receive weather information:

First, connect a power source and an antenna to the radio as described earlier in the manual. Be sure to fully extend the antenna and if you are using the magnetic base, place it near the center of your vehicle's roof.

1. Set the CB/WEATHERADIO switch to A, B, or C.
2. Turn the VOLUME control clockwise so that the radio clicks on. Then, adjust the control for the desired listening level.
3. If reception is poor, try the other two weather station frequencies.

The [PUSH TO TALK], [CHANNEL], [CH9], and [DISPLAY] buttons and the [RANGE] control have no effect on weatheradio operation.

ADDITIONAL CB INFORMATION

CB COURTESY

The Citizens band is open to public use. Therefore, if you exercise common sense courtesy, you'll find that you get a great deal of enjoyment from using your CB.

- Wait for a pause in transmission before asking for a break.
- If you do not receive an answer after the second call to another station, sign off and allow others to use the channel. Wait a while, ask for a break and try again.
- Do not transmit "silence" by holding in the [PUSH TO TALK] button.
- Assist callers with directions, road conditions or other requested information.
- Keep harassment off the air. This is unnecessary and causes problems for everyone, including you.
- Be courteous — treat others the way you wish to be treated.

CITIZENS BAND FREQUENCY CHART

CHANNEL	FREQUENCY	CHANNEL	FREQUENCY
1	26.965	21	27.215
2	26.975	22	27.225
3	26.985	23	27.255
4	27.005	24	27.235
5	27.015	25	27.245
6	27.025	26	27.265
7	27.035	27	27.275
8	27.055	28	27.285
9	27.065	29	27.295
10	27.075	30	27.305
11	27.085	31	27.315
12	27.105	32	27.325
13	27.115	33	27.335
14	27.125	34	27.345
15	27.135	35	27.355
16	27.155	36	27.365
17	27.165	37	27.375
18	27.175	38	27.385
19	27.185	39	27.395
20	27.205	40	27.405

10-CODES

Citizens band radio operators have largely adopted the 10-codes for standard questions and answers. Its use permits faster communication and

better intelligibility in noisy areas. The following table lists some of the more common codes and their meanings.

Code	Meaning	Code	Meaning
10-1	Receiving poorly	10-10	Standing by
10-2	Receiving well	10-13	Advise road/weather conditions.
10-3	Stop Transmitting	10-20	What is your location?
10-4	OK — understood	10-33	Emergency traffic
10-7	Out of Service	10-36	Correct time
10-8	In Service	10-41	Switch to Channel.
10-9	Repeat	10-62	Cannot understand.

NOISE REDUCTION

Because your CB transceiver is exceptionally quiet, any noise you hear is probably from an external source in your vehicle — the ignition, another radio, spark plugs, and so forth.

If you operate the TRC-475 with the vehicle's engine off, you should not have noise problems. If you use the CB with the engine on, you must locate the source of the noise. You can determine the source of the noise by turning off the engine and operating the CB with the ignition set to ACC. If most or all of the noise goes away, the problem is in your vehicle's ignition or electrical system. Here are a few hints to help you reduce or eliminate such noise:

- Do not route the power wires next to antenna wires.
 - Be sure that the ground connection (black wire) is secure.
 - Replace old ignition wires with new, high-voltage, noise-suppression wires.
 - Install noise suppressors on your spark plugs, or install new spark plugs that have built-in suppressors.
 - If problems persist, check your alternator/generator and regulator gauges. Noise from these sources can be reduced or eliminated using bypass capacitors at the various output voltage points.
- Make all CB power and antenna wires as short as possible.

CARE AND MAINTENANCE

Your transceiver is an example of superior design and craftsmanship. The following suggestions will help you care for your transceiver so that you can enjoy it for years.



Keep the transceiver dry. If it does get wet, wipe it dry immediately. Liquids can contain minerals that can corrode the electronic circuits.



Use and store the transceiver only normal temperature environments. High temperatures can shorten the life of electronic devices and distort or melt plastic parts.



Handle the transceiver gently and carefully. Dropping it can damage circuit boards and cases and can cause the transceiver to work improperly.



Keep the transceiver away from dust and dirt, which can cause premature wear of parts.



Wipe the transceiver with a wet cloth occasionally to keep it looking new. Do not use harsh chemicals, cleaning solvents, or strong detergents to clean the transceiver.



Use only fresh batteries of the recommended size and type. Always remove old or weak batteries. They can leak chemicals that destroy electronic circuits.

Modifying or tampering with the transceiver's internal components can cause a malfunction and invalidate the transceiver's warranty. If your trans-

ceiver is not performing as it should, take it to your local Radio Shack store. Our personnel can assist you and arrange for service, if needed.

SPECIFICATIONS

Receiver

Frequency Coverage:	26.965 to 27.405 MHz
Sensitivity (maximum):	0.25 μ V
Adjacent Channel Selectivity:	60 dB (at 10 kHz)
Squelch:	1 mV
Audio Output:	0.5 W (10% THD)
Current Drain:	85 mA to 100 mA

Transmitter

Frequency Coverage:	26.965 to 27.405 MHz
Power Input (at 12 V DC):	5 W
Power Output:	2.5 W
Spurious Emission:	70 dB
Type of Modulation:	A ₃ E
Frequency Tolerance:	\pm 100 Hz
Antenna (Telescopic) Impedance:	50 ohms
Current Drain (No mod.):	600 mA to 800 mA
(Full mod.):	900 mA to 1200 mA

NOTE

RADIO SHACK LIMITED WARRANTY

This product is warranted against defects for 90 days from date of purchase from Radio Shack company-owned stores and authorized Radio Shack franchisees and dealers. Within this period, we will repair it without charge for parts and labor. Simply **bring your Radio Shack sales slip** as proof of purchase date to any Radio Shack store. Warranty does not cover transportation costs. Nor does it cover a product subjected to misuse or accidental damage.

EXCEPT AS PROVIDED HEREIN, RADIO SHACK MAKES NO WARRANTIES, EXPRESS OR IMPLIED, INCLUDING WARRANTIES OF MERCHANTABILITY AND FITNESS FOR A PARTICULAR PURPOSE. Some states do not permit limitation or exclusion of implied warranties; therefore, the aforesaid limitation(s) or exclusion(s) may not apply to the purchaser.

This warranty gives you specific legal rights and you may also have other rights which vary from state to state.

We Service What We Sell

RADIO SHACK
A Division of Tandy Corporation
Fort Worth, Texas 76102